

# Kingtronics®

## RKT-WH

### Carbon Film Potentiometer

#### FEATURES

Electrical Characteristics	
Total Resistance	470Ω-2MΩ
Total Resistance Tolerance	±10%
Resistance Taper	B (Linear)
Max. Operation Voltage	AC 315V
Rated Power	2W
Rotation Noise	≤47mV
Insulation Resistance	≥100MΩ at DC 1000V
Residual Resistance	≤3Ω
Withstand Voltage	1 min at AC 1000V

Mechanical Characteristics	
Total Rotational Angle	300°±5°
Rotational Torque	51~306gf.cm
Stop Torque	8kgf.cm Max.
Shaft Strength/Shaft Lever Strength	pull:5Kg.f Max.
Rotational Life	15,000 cycles

Note: Specifications are subject to change without notice.

#### PICTURE

##### Common Dimensions

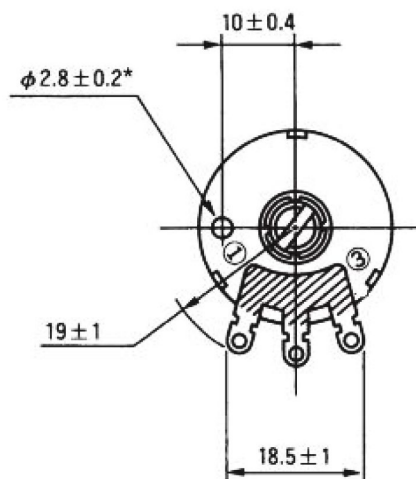
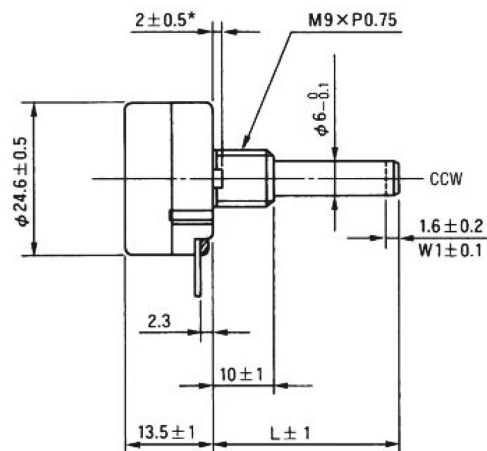

**Kingtronics® International Company**